

opa 218 SUB

onpointaudio™
Acoustic Excellence™



- Dual 18-inch sub with very high output low-frequency response
- High-performance 18-inch woofers with large-format 4-inch voice coils deliver thunderous lows
- Includes heavy-duty rear-mounted casters to make moving easy
- Includes adjustable-height mounting pole for suspension of full-range systems
- Rectangular enclosure with deep narrow profile enhances low bass output
- Vented low-frequency design delivers usable response to 25 Hz
- 136 dB / 130 dB max SPL (Peak / Continuous)
- Heavy-duty marine-grade plywood enclosure with wear-resistant Polyurethane finish

The On Point Audio OPA-218 Sub is a double 18" extremely high-output low-frequency sound reinforcement subwoofer system. The unique geometry provides a large internal volume capable of generating substantial low frequency output. The enclosure was designed for professional bi-amp applications and is bandwidth-optimized for operation between 35 Hz and 80 Hz. Maximum system performance is achieved when DSP-based active filters are implemented in the overall system and a 30-Hz high-order 24 dB-per-octave high-pass filter is used in conjunction with a high order 80-Hz low-pass crossover filter.

The system utilizes a rectangular enclosure geometry. The OPA-218 Sub utilizes dual 18-inch direct radiating, extremely low-frequency transducers, in a configuration that maximizes mutual coupling of the devices and provides additional acoustic output. The OPA-218 Sub is intended for use with On Point Audio systems such as the OPA-15NP and the OPA-15YNP. The OPA-218 Sub is intended for use in professional bi-amp applications only.

The On Point Audio OPA-218 Sub features an 18-mm marine-grade birch rectangular plywood enclosure that utilizes an internal top-mounted loudspeaker pole mount. This allows for a "stacked" extended range system consisting of the sub enclosure and appropriate full-range enclosure. The enclosure is equipped with rear-mounted heavy-duty casters for ease of transportation. The input section consists of two 4-pin Neutrik Speakon connectors and its nominal system impedance is 4 ohms. The OPA 218 Sub may be used with an optional mounting pole.

Specifications

System Type:	Optimally-vented dual 18-inch subwoofer
Frequency Range (-10 dB):	25 Hz - 80 Hz
Frequency Response (-3 dB):	30 Hz - 80 Hz
Power Rating (Peak / Continuous):	6,400 / 1,600 watts
Coverage Pattern:	essentially omnidirectional
Nominal Impedance:	4 ohms
Half-Space Loaded System Sensitivity:	100 dB
Rated Max SPL (Peak / Continuous):	136 dB / 133 dB
LF Driver:	NP18 18-inch
Dimensions (H x W x D) inches:	20.9 x 31.2 x 43.3 in
Dimensions (H x W x D) mm:	532 x 793 x 1100 mm
Included Accessories:	Deluxe casters, adjustable-height mounting pole
Enclosure Material:	Birch Plywood
Net Weight :	176 lb / 80 kg

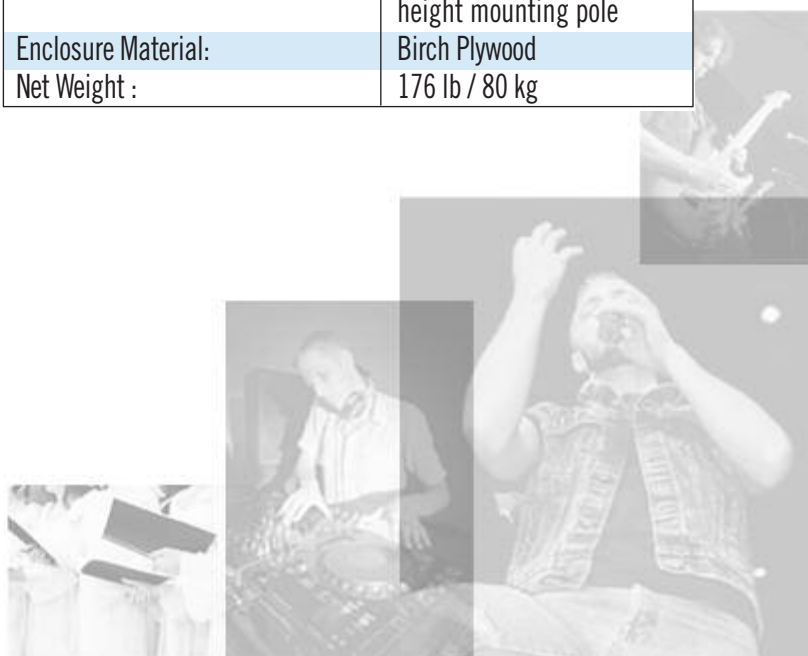

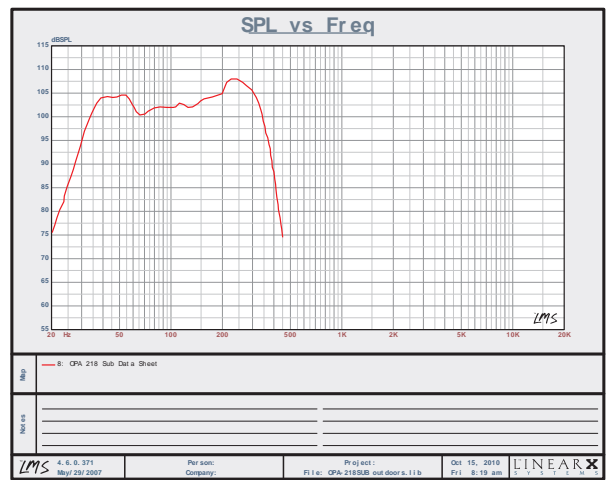
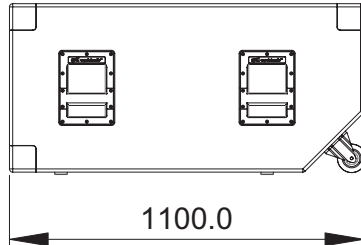
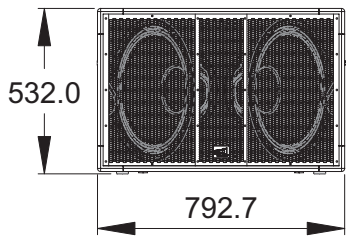
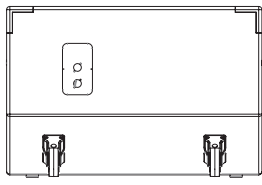
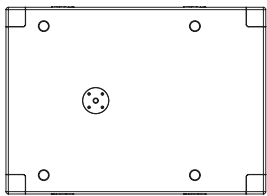
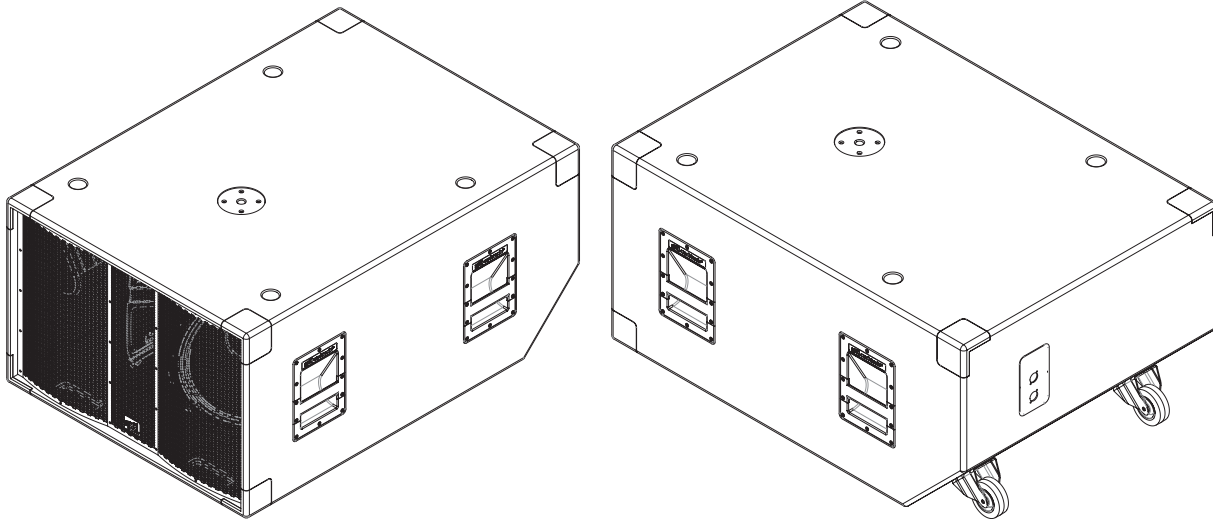

onpointaudio™

Nashville, TN 37215 · 615-815-1705 · www.onpointaudio.com